



# INSTALLATION INSTRUCTIONS

Accessory	Application	Publications No.
MOONROOF VISOR P/N 08R01-TZ5-200	2015 MDX	BII 51634
		Issue Date MAY 2014

## PARTS LIST

Moonroof visor

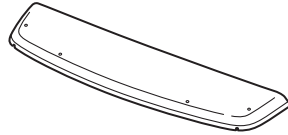

2 Brackets A (marked TZ5 A)

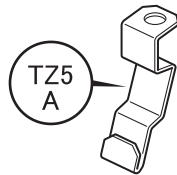

Left bracket B (marked TZ5-L B)

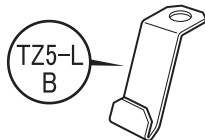

Right bracket B (marked TZ5-R B)

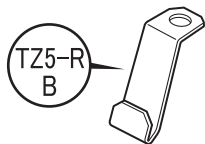

4 Screws



4 Nuts



4 Protective tapes



## TOOLS AND SUPPLIES REQUIRED

Phillips screwdriver

10 mm Combination wrench

Ruler

Isopropyl alcohol

Shop towel

Masking tape

Felt-tip pen

*The following tool is available through the Honda Tool and Equipment Program. On the iN, click on: Service > Service Bay > Tool and Equipment Program, then enter the number under "Search". Or, call 888-424-6857.*

- Torque Screwdriver (T/N CDI401SM)

## INSTALLATION

**Client Information:** The information in this installation instruction is intended for use only by skilled technicians who have the proper tools, equipment, and training to correctly and safely add equipment to your vehicle. These procedures should not be attempted by "do-it-yourselfers."

### NOTE:

- Be careful not to damage the body paint finish.
  - This moonroof visor kit should be installed only if the ambient air temperature is 15°C (60°F) or above.
  - To allow the adhesive to cure, do not wash the vehicle for 24 hours. Please advise the client.
1. Clean and wax the area to be covered with a high-quality paste wax.

- Open the moonroof. Roll up two shop towels, and insert them between the roof panel and air deflector to lower the air deflector. Be careful not to damage the air deflector.

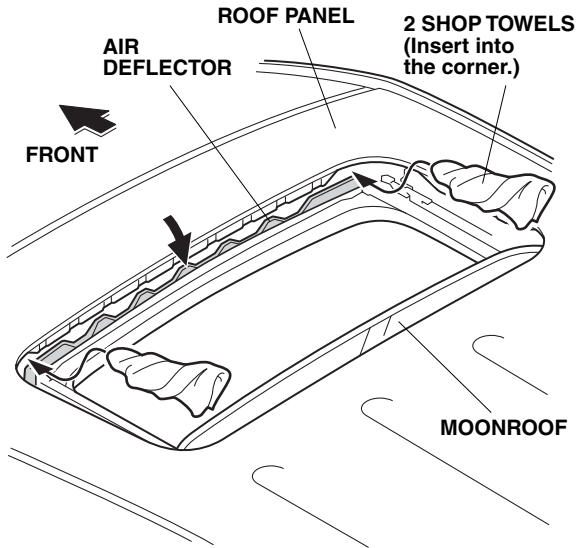

QBN0801AJ

- Measure and make two marks on the roof panel at the measurements shown.

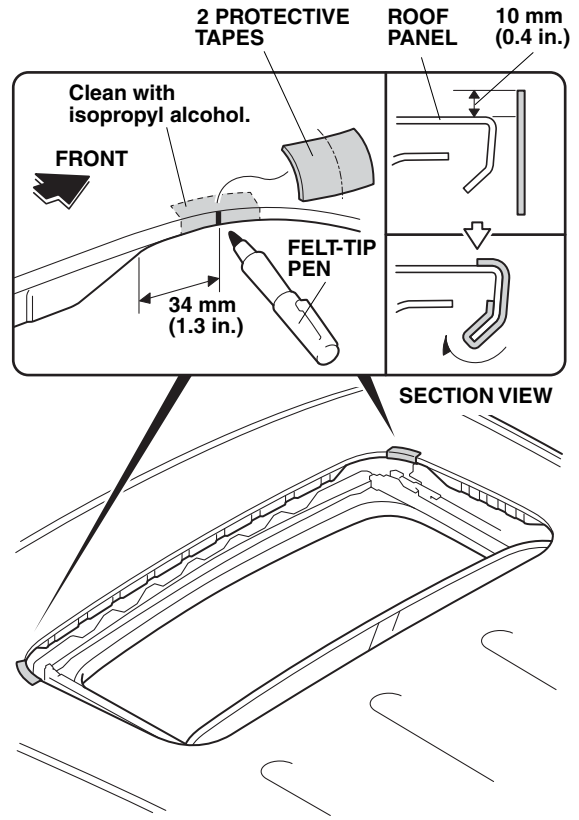

QBN0802BJ

- Using isopropyl alcohol on a shop towel, clean the roof panel at each of the two marks you have made but do not wipe off the marks.
- Remove the adhesive backing from the two protective tapes, and attach one to the roof panel at each of the two marks you made.

6. Locate the second indentations from the right front corner and left front corner of the moonroof opening. Using isopropyl alcohol on a shop towel, clean the roof panel where the protective tapes will attach.

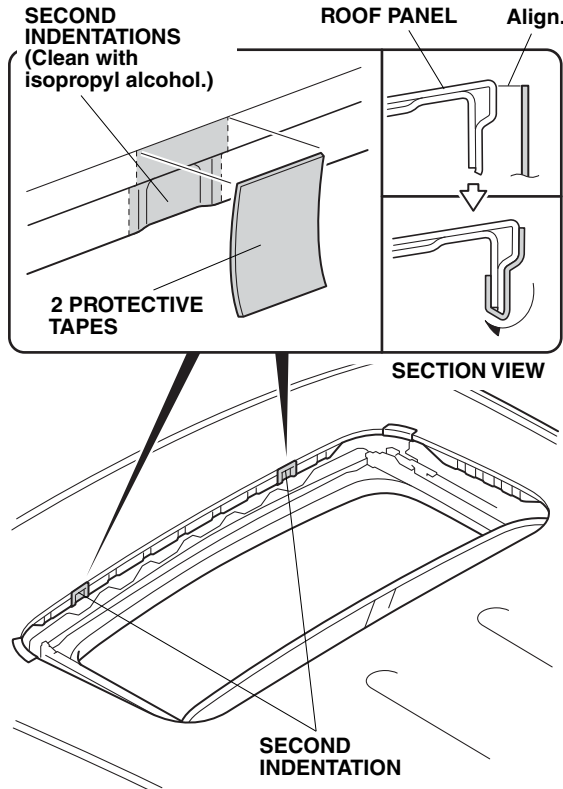

QBN0803AJ

7. Remove the adhesive backing from the two protective tapes, and attach one to the roof panel at each second indentation.

8. Place the left and right brackets B into position over the two protective tapes and around the lip of the roof panel, and tape them into position with the strips of masking tape.

NOTE: Be careful not to crease the protective tape.

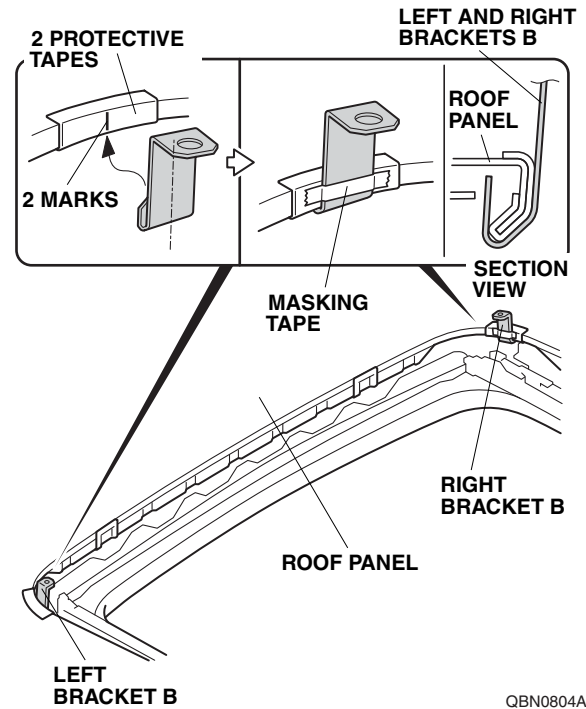

QBN0804AJ

9. Place the two brackets A into position over the two protective tapes and around the lip of the roof panel, and tape them into position with the strips of masking tape. Be sure to align the lower end of the brackets A with the second indentation.   
 NOTE: Be careful not to crease the protective tape.

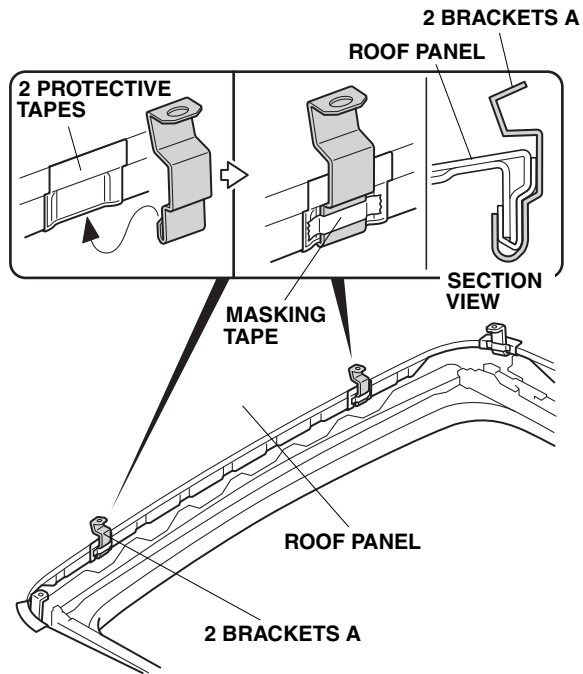

QBN0805AJ

10. Set the moonroof visor on the vehicle roof in front of the moonroof opening, and adjust its position so the holes in the moonroof visor are aligned with the bracket A holes. Loosely install the moonroof visor to the brackets A with two screws and two nuts. Remove the strips of masking tape from the brackets A.

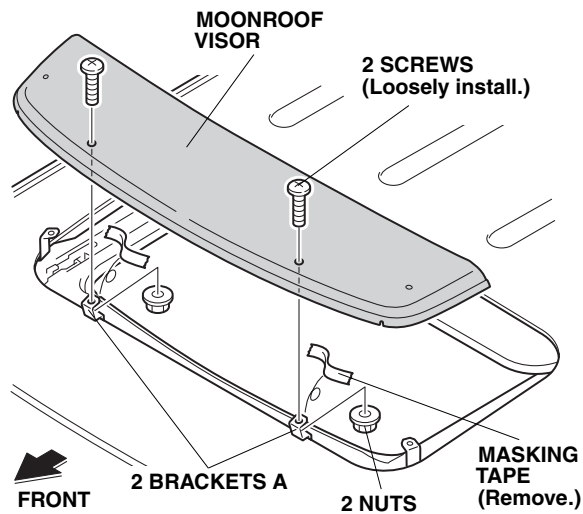

QBN0806AJ

11. Loosely install the moonroof visor to the brackets B with two screws and two nuts. Remove the strips of masking tape from the brackets B.

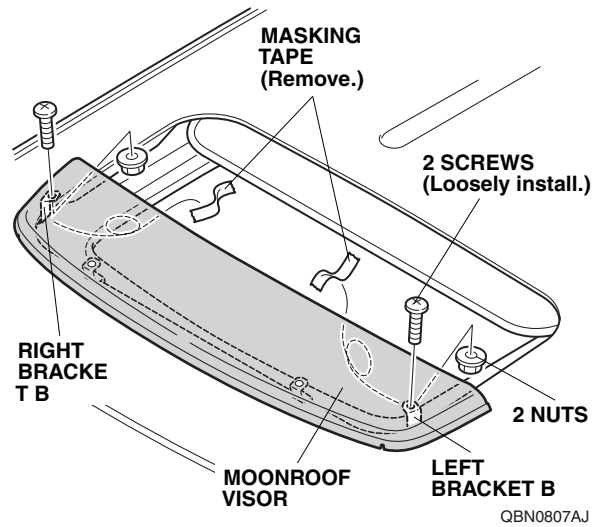

QBN0807AJ

12. Position the moonroof visor with equal spacing in the front and on the sides. Check that the rubber molding is not twisted or rolled under the moonroof visor.

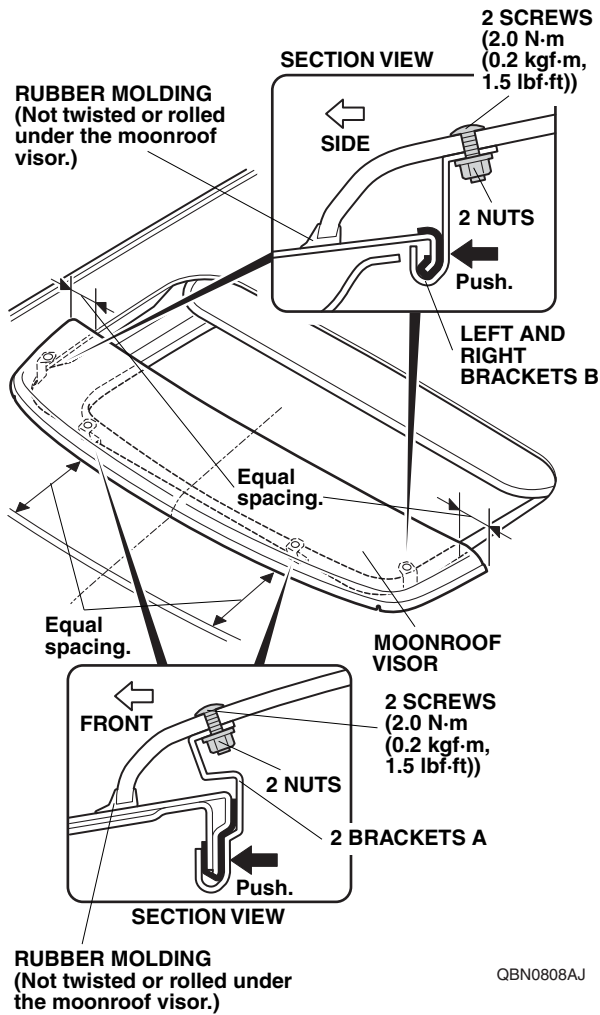

13. Tighten two screws and two nuts on the front of the vehicle first, then tighten two screws and two nuts on each side. Tighten while applying pressure so that there is no gap between the roof panel and the brackets A and B. Torque the screws to 2.0 N·m (0.2 kgf·m, 1.5 lbf·ft).

14. Remove the shop towels inserted in step 2. Remove the IMPORTANT INFORMATION label.

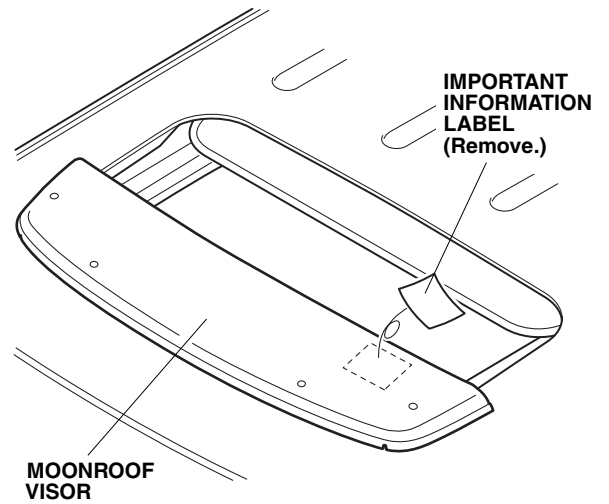

QBN0809AJ

#### CARE OF THE MOONROOF VISOR

- To avoid damaging the surface, do not use organic solvents such as gasoline, ammonia-based cleaners or solvents to clean the moonroof visor.
- Clean with neutral detergent solution and water using a soft cloth or chamois.
- To remove fine scratches and restore the original luster, use Meguiar's Mirror Glaze plastic cleaner and polish or an equivalent high-quality plastic cleaner.